

# DIGITAL FUNCTION GENERATOR

**MODEL:** GFG-8020H

## SAFETY TERMS AND SYMBOLS

These terms may appear in this manual or on the product:



**WARNING.** Warning statements identify condition or practices that could result in injury or loss of life.



**CAUTION.** Caution statements identify conditions or practices that could result in damage to this product or other property.

The following symbols may appear in this manual or on the product:



**DANGER**  
High Voltage



**DANGER**  
Hot Surface



**ATTENTION**  
refer to Manual



Protective  
Conductor  
Terminal



Earth(ground)  
Terminal

# CONTENTS

<b>SECTION 1 GENERAL DESCRIPTION</b>	<b>Page</b>	<b>SECTION 3 THEORY OF OPERATION</b>	<b>Page</b>
Introduction .....	1	General.....	13
Front Panel .....	1	Power Supply.....	13
Rear Panel .....	1	Frequency Controls Circuit.....	14
Printed Circuit Boards .....	2	Constant Current and Triangle Wave Circuit...	14
Electrical Description.....	2	The Formation Circuit of Square wave and Sinewave.....	16
Specification.....	3	Power Amplifier.....	19
		Circuit of Frequency Counter.....	19
<b>SECTION 2 INSTALLATION AND OPERATION</b>		<b>SECTION 4 MAINTENANCE</b>	
Unpacking and Inspection .....	5	Fuse Replacement.....	20
AC Power Requirements .....	5	Cleaning.....	20
Fuse Replacement.....	5		
Controls and Indicators .....	5		
First Time Operation Procedure ....	10		

## ENVIRONMENT CONDITION

Operation Environment : Indoor use : Altitude up to 2000m : Ambient Temperature 0°C to 40°C : Relative Humidity 80%(maximum) : Installation Category II : Pollution Degree	Storage Temperature & Humidity : -10°C to 70°C : 70% (maximum)
---	---

## NOTE



WARNING. For continued fire protection. Replace fuse only with 250V fuse of the specified type and rating, and disconnect the power cord before replacing fuse.



WARNING. To avoid electrical shock, the power cord protective grounding conductor must be connected to ground.



CAUTION. To avoid damaging the instrument, don't use it in a place where ambient temperature exceeds 40°C.



CAUTION . To avoid damaging the instrument, V.C.F. (V.C.G.) do not input more than DC15V.

## SECTION 1 GENERAL DESCRIPTION

### INTRODUCTION

The DIGITAL FUNCTION GENERATOR provides square, triangle, sine, ramp and pulse waveforms over a frequency range from 0.2 Hz to 2 MHz, plus a VCF input, variable DC offset and TTL or CMOS pulse output.

The built-in frequency counter for measuring internal oscillation frequency.

### FRONT PANEL

The main output and all controls are located on the front panel. They are: the push button POWER switch, seven frequency RANGE push button switches, three push button FUNCTION switches, frequency MULTIPLIER (variable), DUTY potentiometer with invert switch, DC OFFSET control with level control, output AMPLITUDE control with output attenuation, OUTPUT, VCF (voltage controlled frequency) input, TTL or CMOS pulse output, CMOS level control with CMOS/TTL selector SW, counter display, M.k.m. and Hz indicator, Gate signal indicator.

### REAR PANEL

On the rear panel is located the power cord receptacle.

## PRINTED CIRCUIT BOARDS

**Main Generator:** All circuitry and the power supply are contained on the main P.C. board. All controls and the POWER switch are also contained on the main P.C. board.

**FREQUENCY COUNTER:** The frequency counter is contained on the main P.C.board.

## ELECTRICAL DESCRIPTION

The DIGITAL FUNCTION GENERATOR utilizes two constant current sources of opposite polarity for charging and discharging a timing capacitor to produce the triangular waveform.

A sinewave shaping network shapes the triangle to produce the low-distortion sine wave. The level detector senses the voltage on the timing capacitor and connects and disconnects the current sources alternately. The square wave produced by the level detector is utilized to produce the output square wave.

## SPECIFICATIONS

Specifications are listed below in table 1-1.

Theory of operation is given in section 3.

Table 1-1 Specifications

Main Generator	
Frequency Range	0.2Hz to 2MHz (7 Ranges) 4 digits display with coarse/fine tuning.
Frequency Accuracy	Please reference to counter accuracy
V.C.F. (Voltage Controlled Frequency)	Approx. 0 to 10V ( $\pm 1V$ ) input for 10 : 1 frequency ratio input impedance, Approx. 10K $\Omega$
Main Output Wave Forms	Sine, triangle, square, pulse and ramp
Amplitude	> 20V p-p open circuit > 10V p-p into 50 $\Omega$
Attenuation	- 20dB & continuously variable
DC offset	Variable +10 to -10V open circuit, +5 to -5V into 50 $\Omega$
Sine Wave	Distortion: 0.2Hz-20KHz $\leq 1\%$ Response: 0.2Hz-100KHz $\leq 0.2dB$ 100KHz-2MHz $\leq 1dB$
Square wave	Rise Time < 120nS

Pulse Output	
Rise time	< 30 nS
Level	Amplitude Fixed >+3V open circuit
CMOS Level	(4V±1V)p-p to (14.5V ± 0.5V)
Frequency Counter	<p>a. INT only</p> <p>b. Accuracy: ±Time Base accuracy ± 1 count.</p> <p>c. Time Base: Oscillation frequency 10MHz. Temp. Stability 23°C ±5°C ±1 × 10<sup>-5</sup></p> <p>d. Counting Capacity: 4 digit (0.5" LED display)</p> <p>e. Resolution: 100nHz, mHz, 10mHz, 100mHz, Hz, 10Hz, 100Hz, KHz.</p>
Power Source	AC 100, 120, 220, 230V ± 10% 50 / 60 Hz
Accessories	Test lead GTL-101 x 1 Instruction Manual x 1
Dimension	245 (W) x 95 (H) x 280 (D) mm
Weight	2.5kgs

## SECTION 2 INSTALLATION AND OPERATION UNPACKING AND INSPECTION

THE DIGITAL FUNCTION GENERATOR is packaged to absorb any reasonable shock encountered during shipping.

Carefully remove the instrument from the shipping container and inspect for shipping damage. If damage is found, notify the carrier immediately.

### AC POWER REQUIREMENTS

This instrument operates on line voltages of either 100V, 120V, 220V, 230V AC  $\pm$  10% 50-60Hz, power dissipation approx. 15VA.

### FUSE REPLACEMENT

If for some reason the fuse blows, first try to determine the cause of the failure and remedy if possible.

NOTE: Replace with the proper size fuse only to prevent damage to the instrument.

## CONTROLS AND INDICATORS

### POWER SWITCH

The power switch applies power to the function generator.

### RANGE SWITCH

Seven fixed decades of frequency are provided by the RANGE pushbutton switch. Each of the seven pushbutton RANGE switches is interlocked. Depressing one pushbutton will release all others.

## FUNCTION SWITCH

Three interlocking pushbutton switches provide selection of the desired output waveform. Depressing one switch will release the switch previously depressed. Square, triangle, and sine waveforms are provided, satisfying most applications.

## MULTIPLIER

The MULTIPLIER is a variable potentiometer allowing frequency settings between fixed ranges.

## DUTY CONTROL WITH INVERT

Time symmetry of the OUTPUT waveforms, as well as the TTL or CMOS PULSE output, is controlled by the DUTY potentiometer.

When this control is set to the CAL position, the time symmetry of the output waveforms is 50/50 or approximately 100% symmetrical.

The variable symmetry allows the time period of one-half the waveform to be changed while the other half remains fixed as determined by RANGE and MULTIPLIER settings. This unique feature provides variable pulse width and variable duty cycle pulses.

The duty control potentiometer with INVERT switch when pull position is provided to invert the time symmetry set by the Duty control.



Table 2-1 illustrates the effect of the INVERT switch and DUTY control ( Square and pulse output only )

NOTE: The time symmetry as illustrated below is for reference only.  
 Any desired time symmetry ratio may be set as desired within the limits as described in Section 3, DUTY.

Table 2-1 Duty Control

DC OFFSET WITH LEVEL CONTROL

A DC OFFSET control (DC offset control potentiometer in pull position) is provided to allow the DC level of the OUTPUT waveforms to be set as desired.

NOTE: The amount of offset plus the amplitude setting can't exceed the maximum p-p amplitude, otherwise clipping will occur.









Ramp/Pulse Invert Switch	Duty Control	Square	Pulse Output
pull	Cal		
push	Cal		
push	Max CW		
pull	Max CW		

Table 2-1 DUTY Control

Table 2-2 below illustrates the effect of the DC OFFSET control. The clipped waveform is caused by too much amplitude and too much offset.





Offset	Amplitude	Output
0	Max	 +10V -10V
Max CW	Max	 +10V 0V
Max CCW	Max	 0V -10V
Mid CW	Max	 +10V -10V
Mid CCW	Max	 +10V -10V

Table 2-2 DC OFFSET Control

#### AMPLITUDE WITH ATT

The AMPLITUDE control provides 20dB of attenuation of the output waveform selected by the FUNCTION switch. When the switch is pull, in addition to 20dB provided by amplitude control, a maximum of 40dB of attenuation, at the output.

## OUTPUT

Square, triangle, sine, and pulse waveforms are provided at up to 20V p-p amplitude (open circuit) at the OUTPUT (When ATT pushbutton switch is pushed).

The VCF input and PULSE outputs, utilize BNC connectors.

## VCF INPUT

A VCF ( voltage-controlled frequency ) input is provided for externally sweeping the frequency. Approximately +10V applied at the VCF input will sweep the generator frequency down to 10:1. The generator may also be swept up in frequency by applying a negative voltage at the VCF input.

## PULSE OUTPUT

The PULSE OUTPUT is a TTL or CMOS output signal suitable for driving TTL or CMOS logic. The rise and fall time of the PULSE output is typically 25ns. The pulse width and repetition rate may be set as desired, utilizing the RANGE and MULTIPLIER and DUTY control. The symmetry of the PULSE output is controlled in the same manner as the output waveforms described in Table 2-1.

## CMOS LEVEL CONTROL

The CMOS LEVEL CONTROL potentiometer (pull position) provides CMOS LEVEL OUTPUT from 5V to 15V continuously variable.

### PULSE OUTPUT SWITCH

Depress the potentiometer switch and observe the TTL and CMOS output push is TTL, pull is CMOS.

### FREQUENCY COUNTER COUNTER DISPLAY

LED indicator display measured internal frequency.

### GATE LED

Gate signal indicates when push the gate time switch.

NOTE: Before applying power to the Digital FUNCTION GENERATOR, be sure the proper line voltage is available.

Plug the power cord into the proper source of 110V AC 50-60Hz. All instruments are wired for 110V AC unless otherwise order made.

### FIRST TIME OPERATION PROCEDURE

Set the digital function generator controls as follows:

RANGE-Hz	10K
MULTIPLIER	Max. CW
FUNCTION	
DUTY	CAL
AMPLITUDE	MAX
OFFSET	PUSH
ATTENUATOR	0dB

#### MAIN OUTPUT

Connect an oscilloscope to output.  
Observe a 20Vp-p 20KHz (approx.) triangle wave.

#### FUNCTION SWITCH

Select and observe a 20V p-p square wave and sine wave.

#### AMPLITUDE CONTROL

Rotate the AMPLITUDE vernier from maximum to minimum and observe greater than 23dB of attenuation.

#### ATTENUATION

Connect the oscilloscope to the OUTPUT and push the ATT pushbutton switch that the signal is attenuated by a factor of 20dB.

#### DC OFFSET

Reconnect the oscilloscope to the OUTPUT and select the triangle waveform. Rotate the DC OFFSET control potentiometer (pull position) and observe the peaks of the triangle waveform will "clip" when the DC OFFSET plus the peak amplitude exceeds  $\pm 10V$ .

Reduce the output amplitude and observe the amount of DC OFFSET may be increased by the same amount the peak amplitude has been decreased.

Return the potentiometer to "PUSH" position and the AMPLITUDE to maximum.

## DUTY CONTROL

While observing the square waveform on the oscilloscope, rotate the DUTY control CW from the CAL position.

Observe one slope of the square remains constant while the other slope is variable over typically a 10:1 range, producing a pulse waveform.

## INVERT SWITCH

Depress the INVERT potentiometer (pull position) and observe the positive and negative slopes of the pulse waveform reverse (invert)

By selecting the Square wave and repeating the same procedure, this model DIGITAL FUNCTION GENERATOR become very versatile pulse generators.

The pulse width may be determined by the following formula:  
PULSE WIDTH = the reciprocal of 2 X freq. setting.

In other words, the pulse width equals one-half the time period of the frequency set by the RANGE and MULTIPLIER controls.

## PULSE OUTPUT

Connect the oscilloscope to the PULSE output.

By adjusting the generator frequency, the DUTY control and the INVERT switch, the high-speed TTL pulse or CMOS pulse may be utilized as a very versatile pulse generator. With the INVERT switch in the NORM position, the pulse width "on time" is determined by the RANGE and MULTIPLIER setting and the repetition rate "off time" is set by the DUTY control.

NOTE: When the INVERT switch is set to INVERT, the pulse "off time" is determined by the RANGE and MULTIPLIER setting and the pulse "on time" is set with the DUTY control.

### SECTION 3 THEORY OF OPERATION

#### GENERAL

This section describes the operation of this DIGITAL FUNCTION GENERATOR .

#### POWER SUPPLY

There is two parts for second winding of transformer used by this function generator. One is 18V AC full wave 300mA, and the other is 9V AC half wave 300mA. 18V AC rectified by BD101 & filtered by C101, C102, then output +24V and -24V (with load). +24V regulated by U101 and then get stabilized +15V. It will go through U103 and be regulated to get +5V. Meanwhile it will be regulated by Q101,U102 to get -15V; by Q102 to get -5V.

In order to prevent work of frequency counter from being affected by the circuit of function generator, U104 supplies independently +5V stable voltage to the circuit of frequency counter.

## FREQUENCY CONTROLS CIRCUIT

This unit is composed by U201 which controlled frequency in the instrument, but actually it is achieved by controlling voltage, V202 which undertakes this mission. U201 is used for VCF input invert amp. when VCF input is 0V, the 6th pin of U201 is also 0V. If VCF input is +10V, the 6th pin will gain -13V voltage and make control voltage of VR202 controlled by VCF input voltage, then input control voltage get by VR201, to constant current generator circuit.

## CONSTANT CURRENT AND TRIANGLE WAVE CIRCUIT

This unit is the heart of the instrument. It includes constant current driving circuit U203, Q203, positive current source U204, Q202; diode switch D201, D202; timing capacitor C203-C207; voltage follower Q204-Q206, differential level detector and flip-flop U301, negative constant current is made by U205, Q203, which U203, Q203 is called as current source. As far as U204, U205 is concerned, U205 is also called as "constant current driving circuit".

As circuit diagram Figure 6-1, differential input of OPA  $\dot{\div}$  0V, so  $V_e = -V_{in}$ ,  $I_e = I_c + I_B$ ; and  $I_c \gg I_B$ , therefore  $I_e \dot{\div} I_c$ . If  $R_c = R_e$  and to add equivalent voltage but contrary polarity on it ( +15V and -15V ), then  $I_c = I_e$   $V_c = V_e$ .

This circuit uses OPA No. UA741, and its  $I_B$  current is only approximate 0.1UA. If  $I_c$  works within mA current range, then  $I_c = I_e$  is reasonable. Now to change transistor to FET,  $I_B$  is in the stage of PA (UUA), and therefore  $V_{in} = V_e = V_c$ . i.e. to control not only  $V_{in}$  Voltage but also constant current



At figure 6-2 stated the formation way of triagnle wave. If  $I_1$ ,  $I_2$  are two groups of constant current source, and  $I_1 = 2I_2$  when P point voltage is higher than A point voltage, then there is a charge current  $I_A$  available  $I_A = I_1 - I_2 = I_2$ . Therefore  $V_c$  voltage will slowly go up.

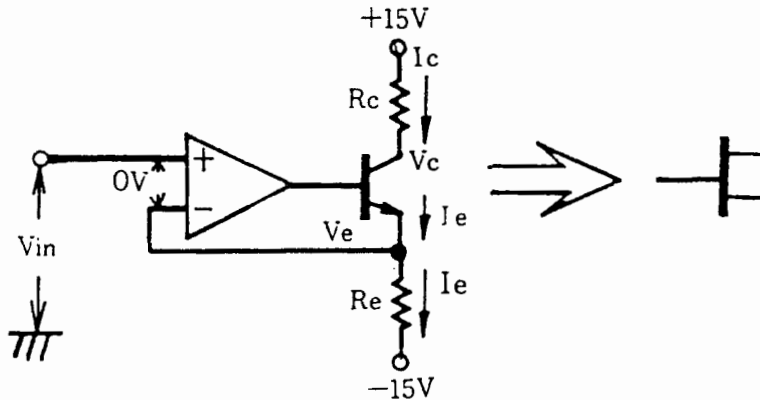

FIGURE 6-1

When P point voltage is lower than B point, there is  $I_3$  current available and  $I_3 = I_1$ , i.e.  $I_A = 0$ . However,  $I_2$  is constant current source, and it permanently needs current source, therefore, there is discharge current  $I_B$  available and  $I_B = I_2$ , so  $V_c$  voltage will slowly come down. Thus come out triangle waves circulatively.

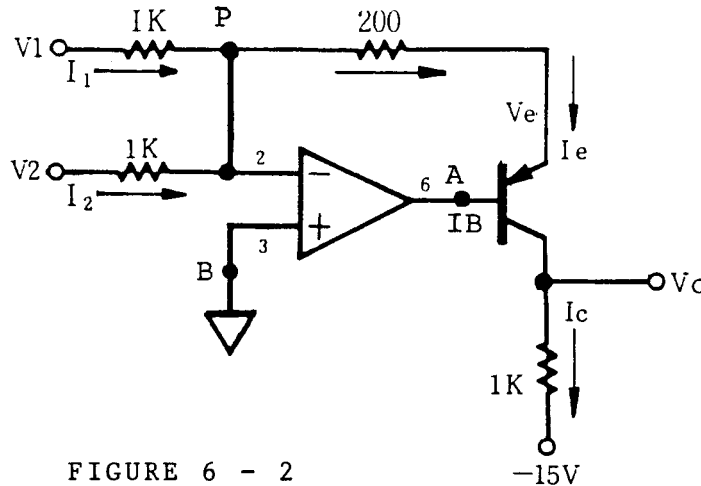

FIGURE 6 - 2

### THE FORMATION CIRCUIT OF SQUARE WAVE AND SINEWAVE

This unit including U401, U302, U303 etc., the formation of square wave is made by using a flip-flop to produce square form and phase shift R318, R319, R320 are in charge of this mission.

VR301 is for fine adjustment of square wave amplitude; R313 is for TTL output buffer resistor, it can reduce phenomena of overshoot and ringing. Sinewave is made by using triangle wave to make non-linear amplification, and in the instrument to attenuate triangle wave in advance. (made by R403, and R404) and then make non-linear amplification, phase shift etc. (made by U401) and again to input power stage and amplify. VR401 is to adjust clip point of sinewave, i.e. course adjustment of sinewave distortion. VR403 is to adjust the symmetry of sinewave, i.e. fine adjustment of sine wave distortion, R405-R407 are "differential state Re resistor", to supply constant current. VR404, R408 are load resistor of differential output to take resistance and signal output into positive ratio relation, to adjust VR404 to get the "GAIN".

Two transistors at the right side of U401 are in charge of the work of phase shift, because the output of the 8th pin is constantly positive signal source. To adjust VR402 can make U401 its 14th pin output be zero D.C. offset of A.C. sinewave. R401, R402 are decoupling resistor. C401, C402 are decoupling capacitor. R412 supplies VB bias.

U303 is in charge of CMOS level output, and its output amplification is taken from VR302, then via TTL/CMOS selective switch output to BNC at the front panel, while Q301 is in charge of TTL level to increase to CMOS level, because Q301 output via collector has inverter function. Therefore, output at TTL and then via another AND GATE to couple the signal here.

The most important point of above description is how to control P point voltage, when it will be “1”, and when it will be “0”. In FIGURE 6-3 there are two comparator at left side, and one SR flip-flop at right side.

To examine truth table of SR flip-flop when  $S=0, R=1$ , Q constantly is 0. When  $S=1, R=0$ , Q constantly is 1. Now to prevent status of flip-flop from being confused (i.e.  $S=R$ ). If  $S=\bar{R}, R=\bar{S}$ , when  $S=1, R=0$  or  $S=0, R=1$ , therefore to connect constantly the inverter input of A comparator with +1V, and the non-inverter input of B comparator with -1V.

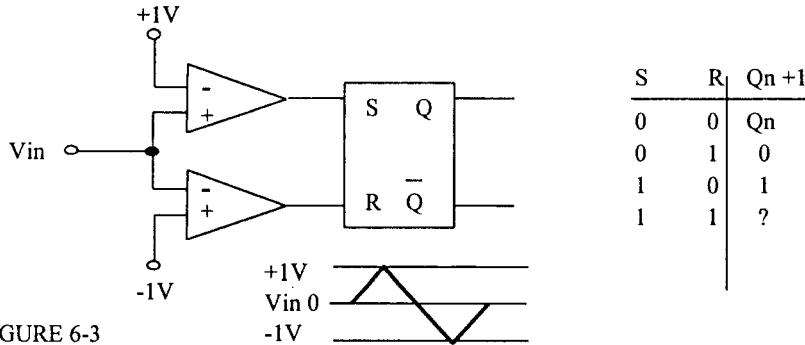

FIGURE 6-3

When  $V_{in}$  voltage exceed +1V, A comparator output is positive and B comparator output is negative. i.e.  $S=1, R=0$ , so  $Q=1, \bar{Q}=0$ . When  $V_{in}$  voltage less than -1V, B comparator output is positive and A comparator output is negative. i.e.  $R=1, S=0$ , so  $\bar{Q}=0, Q=1$ . From this result we can get the action of  $\bar{Q}$  matching request of controlling voltage P point shown in figure 6-2. Doing this way Circulatively can obtain triangle wave.

## POWER AMPLIFIER

This unit includes Q501-Q507 and attenuator. Any waveform passed through Function Switch and entered VR502 and R501 to get divided voltage and then amplify again. VR502 is the amplification adjustment for the instrument and has adjustment range of 20dB. Its adjustment ratio =  $\frac{VR502 + R501}{R501}$   
=  $\frac{1K + 12}{12} \approx 100$  (time)  $\approx 40$ dB. Q501 and Q502 make differential amplifier and its amplification ratio is determined by the R511 and R510 its ratio value, amplification ratio  $A = \frac{R511}{R510} = \frac{18K}{2K} \approx 9$  (time), i.e. input 2.5Vp-p signal after amplified its amplification will be larger than 20Vp-p. VR501 is internal D.C offset adjustment; VR503 is external DC offset adjustment. Its theory is that to input one positive or negative DC level to Q502; base makes deflection of differential output to positive or negative.

Q504, Q505 are to compensate V bias; Q506 and Q507 are typical pushpull power output, and its purpose is to amplify current; its voltage gain constantly is 1, R516 and R517 prevent class-AB pushpull amplification from making crossover distortion.

C502 and C503 are decoupling that can reduce output, because supply source noise makes interference. R518 and R519 are the output impedance of the instrument. R520, R521 construct attenuator, its attenuation is -20dB effect. Output impedance is still maintained at 50Ω (OHM).

## CIRCUIT OF FREQUENCY COUNTER

U601 (GFC 9701) is the main part of this unit. The Frequency Counter is an ASIC which developed by our company.

## MAINTENANCE

The following instructions are use for by qualified only. To avoid electrical shock, do not perform any servicing other than contained in the operating instructions unless you are qualified to do so.

### 1. FUSE Replacement:

If the fuse bolws, the FUNCTION GENERATOR will not operate. Try to determine and correct the cause of the blown fuse, then replace only with a fuse of the correct rating and type, as shown below.

MODEL	FUSE Rating and Type		Rating Input	
	100V-120V	220V-230V	Watts	VA
GFG-8020H	T 0.5A 250V	T 0.315A 250V	11	16

### 2. Cleaning:

To keep the instrument clean, wipe the case with a damp cloth and detergent. Do not use abrasives or solvents.

## FOR UNITED KINGDOM ONLY

### NOTE

This lead/appliance must only  
Be wired by competent persons

### WARNING

THIS APPLIANCE MUST BE  
EARTHED

### IMPORTANT

The wires in this lead are  
coloured in accordance with  
the following code:

Green/  
Yellow: Earth  
Blue: Neutral  
Brown: Live (Phase)



As the colours of the wires in main leads may not correspond with the colours marking identified in your plug/appliance, proceed as follows:

The wire which is coloured Green & Yellow must be connected to the Earth terminal marked with the letter E or by the earth symbol  $\oplus$  or coloured Green or Green & Yellow.

The wire which is coloured Blue must be connected to the terminal which is marked with the letter N or coloured Blue or Black.

The wire which is coloured Brown must be connected to the terminal marked with the letter L or P or coloured Brown or Red.

If in doubt, consult the instructions provided with the equipment or contact the supplier.

This cable/appliance should be protected by a suitably rated and approved HBC mains fuse :refer to the rating information on the equipment and/or user instructions for details.

As a guide, cable of 0.75mm<sup>2</sup> should be protected by a 3A or 5A fuse. Large conductors would normally require 13A types, depending on the connection method used.

Any moulded mains connector that requires removal/replacement must be destroyed by removal of any fuse & fuse carrier and disposed immediately, as a plug with bared wires is hazardous if a engaged in live socket. Any re-wiring must be carried out in accordance with the information detailed on this label

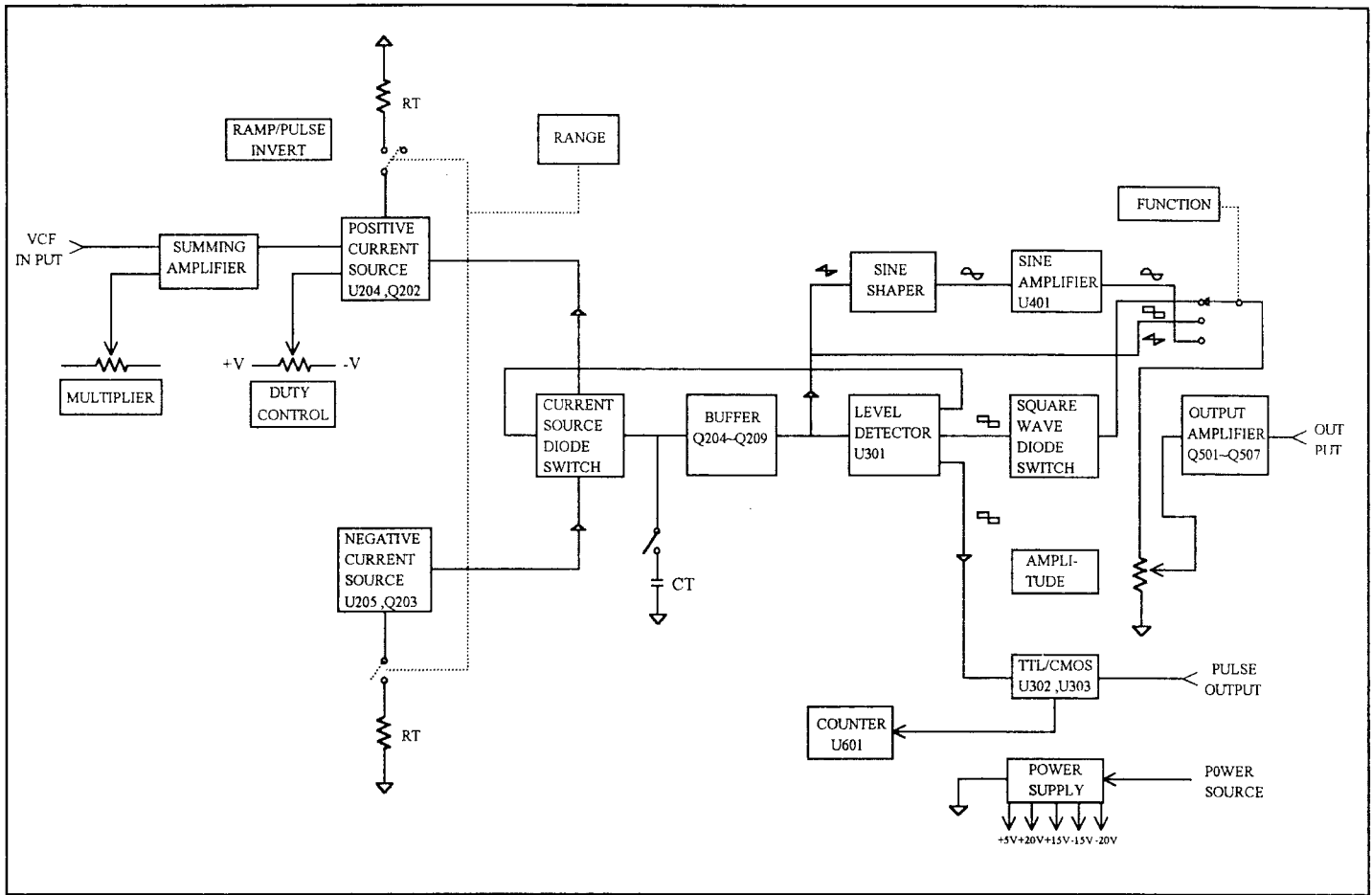

BLOCK DIAGRAM ( GFG-8020H )

## EC Declaration of Conformity

**We**

**GOOD WILL INSTRUMENT CO.,LTD.**

(1) NO. 95 - 11, Pao Chung Rd., Hsin-Tien City, Taipei Hsien, Taiwan

(2) Plot 522, Lorong Perusahaan Baru 3, Prai Industrial Estate, 13600 Prai, Penang, Malaysia

declare, that the below mentioned product

**GFG-8020H**

are herewith confirmed to comply with the requirements set out in the Council Directive on the Approximation of the Law of Member States relating to Electromagnetic Compatibility (89/336/EEC,92/31/EEC,93/68/EEC) and Low Voltage Equipment Directive(73/23/EEC).

For the evaluation regarding the Electromagnetic Compatibility and Low Voltage Equipment Directive, the following standards were applied:

<b>EN50081-1: Electromagnetic compatibility - (1992) Generic emission standard Part 1: Residential, commercial and light industry</b>			<b>EN50082-1: Electromagnetic compatibility - (1992) Generic immunity standard Part 1: Residential, commercial and light industry</b>		
Conducted Emission	EN 55022	class B	Electrostatic Discharge	IEC 1000-4-2	(1995)
Radiated Emission	(1994)+A1(1995)+A2(1997)		Radiated Immunity	IEC 1000-4-3	(1995)
Current Harmonics	EN 61000-3-2	+ A12 (1996)	Electrical Fast Transients	IEC 1000-4-4	(1995)
Voltage Fluctuations	EN 61000-3-3	(1995)	Surge Immunity	IEC 1000-4-5	(1995)
-----	-----	-----	Voltage Dip/Interruption	EN 61000-4-11	(1994)
<b>EN50081-2: Electromagnetic compatibility - (1993) Generic emission standard Part 2: Industrial Environment</b>			<b>Low Voltage Equipment Directive 73/23/EEC</b>		
Conducted Emission	EN 55011	class A	Low Voltage Directive	EN 61010-1:(1993)+A2:(1995)	
Radiated Emission	(1991)				